



Passport 1612G and Passport 1624G



Passport 1648T

Nortel Networks

Passport 1600 Routing Switch

Passport 1600 benefits

- *Strengthens resiliency for the network core*
- *Increases convergence application performance*
- *Ensures security for discreet network traffic*

As competition grows for customers in the marketplace, enterprises are relying on technology to help them differentiate their business. Many of the applications used to provide services and increase productivity require reliable, secure communications. Network resiliency,

security of data, and application-driven performance are the mainstays of a network built to provide services.

Aggregating network traffic from wiring closets and servers provides increased network performance and aids in troubleshooting. By aggregating wiring closet traffic into a hardware-based routing switch, inter-network traffic can be routed at wire-speed, ensuring application response times, required by bandwidth-sensitive applications, are met. Additionally, fewer high-speed router ports are required since high-speed wiring closet links are consolidated before connecting to the WAN router. Troubleshooting is made easier by providing clear distinctions for traffic segmentation.

The Passport* 1600 is a high-performance fixed port Layer 3 solution that provides the resilience, performance, and security required by today's application and

competition-driven enterprise networks. Delivering application performance with proven reliability allows businesses to differentiate themselves with tools for everything from customer service to productivity or collaboration. Resiliency delivers maximum availability critical for bandwidth-sensitive and revenue-generating applications. Application performance decreases the chance that data will be dropped when traffic load increases on the switch. Security features provide added protection for switch configuration data, while packet filtering helps secure and segment sensitive traffic or network access.

Figure 1: Aggregation

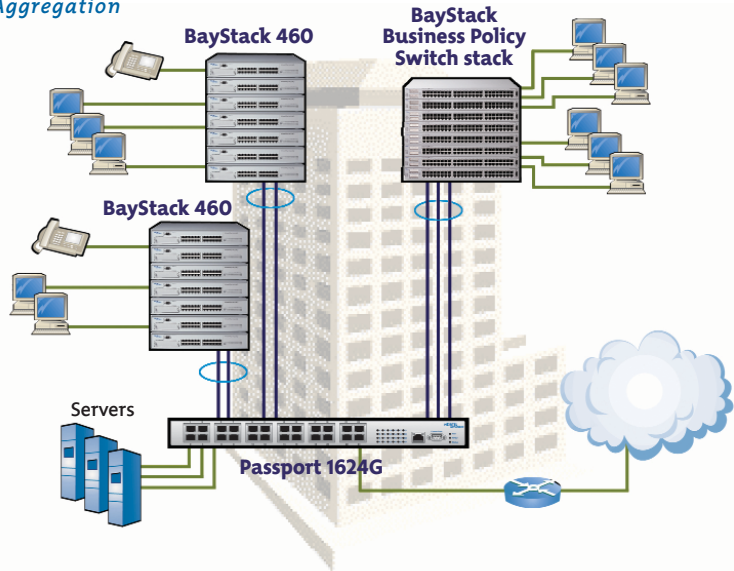

The Passport 1600 is available in three models:

- Passport 1648T with 48 10/100 ports plus 4 connections for small form pluggable (SFP) GBICs
- Passport 1612G with connections for 12 SFP GBICs
- Passport 1624G with connections for 24 SFP GBICs

The Passport 1600 series provides a unique fixed port routing switch solution designed to provide the resiliency, performance, and security required by today's application-driven networks.

Resiliency

The Passport 1600 Routing Switch provides increased reliability for small network cores. Dual redundant power supplies ensure maximum availability of networking hardware. Support for Split Multi-link Trunking (SMLT)[†] and Link Aggregation (802.3ad static compliant) provides redundant load sharing connections to one or more desktop switches. Resiliency is addressed at multiple layers ensuring the highest availability of resources and the lowest network downtime.

Split Multi-link Trunking (SMLT) and Link Aggregation

Link Aggregation support allows up to four ports to be grouped as a single trunk, providing increased bandwidth and resilient connections. Combined with Nortel Networks unique SMLT technology, switches can be dual homed or have multiple active connections to a network core. By utilizing these dual connections and bypassing traditional solutions like Spanning Tree Protocol, customers can increase available bandwidth and decrease network downtime with a simple keystroke. Customers can now increase reliability and performance without restructuring the network.

[†]Supported in a future release.

Convergence-based performance

Application performance minimizes packet delay and jitter when the traffic load increases on the switch. Wire-speed routing and Quality of Service (QoS) mechanisms deliver the performance required for applications such as IP telephony, as well as multimedia and collaboration applications. A non-blocking switch fabric, together with hardware-based routing, decrease the chance that data will be dropped when the traffic load increases on the switch. The policing and shaping features[†] permit traffic flows to be controlled based on applications needs. With support for 48 10/100 ports (Passport 1648T) or up to 24 SFP GBIC ports (Passport 1624G), application performance can be delivered anywhere in the network.

QoS

Being able to classify, process, and expedite traffic based on an application's requirements are more important than ever. QoS and the ability to prioritize traffic are what enables a switch to support bandwidth-sensitive applications. By assigning QoS levels to traffic flows, applications can get the bandwidth and network priority demanded by specific applications. Four priority queues are the basis for QoS in the Passport 1600. Combined with wire-speed routing and filtering, the Passport 1600's QoS features enable application-based solutions to be implemented when and where you need them most.

Routing performance

Wire-speed routing and a non-blocking switch fabric provide the basis for a network designed to increase collaboration and productivity. IP telephony, Customer Relationship Management (CRM), and collaboration applications promise great increases in employee productivity. However, these applications have stringent requirements on the network. The Passport 1600 is designed to be able to route, filter, and queue traffic so that no data is lost, dropped, or delayed. Applications get the bandwidth they need, when they need it, without delay or jitter.

Security

Security features provide added protection for switch configuration data, while packet filtering helps secure and segment sensitive

Figure 2: Network edge

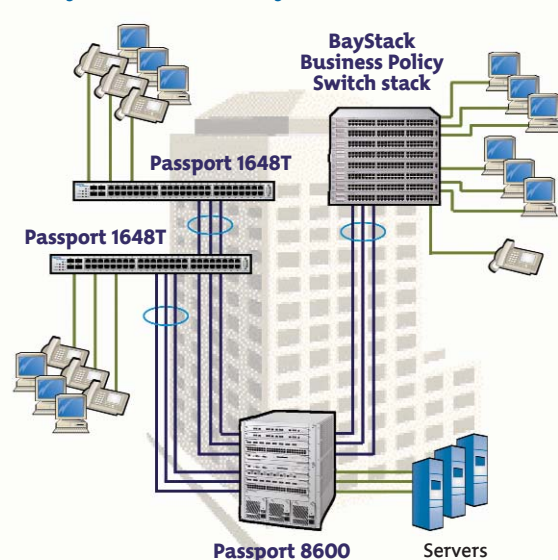

traffic or network access. Support for Simple Network Management Protocol (SNMPv3)[†] and Secure Shell (SSHv2) supply protection for sensitive switch configuration data. Multi-level access and defined access policies help secure the switch against unauthorized management access. Packet filtering provides an additional means to segment and secure sensitive traffic or network access. Support for RADIUS and TACACS+ give customers the freedom to use current security databases.

Simple Network Management Protocol and Secure Shell

Altering device configurations or eavesdropping on configuration command sessions represents real security concerns. Switch configuration information and its integrity are critical to maintaining a mission-critical network. The Passport 1600 supports SNMPv3[†] and SSHv2 for controlling switch configuration information. SNMPv3 provides services for sending and receiving messages, authenticating and encrypting messages, and controlling access to managed objects. SSH specifies the way to conduct secure communications over a network. Together these protocols help ensure that access to critical network resources, like the Passport 1600, is maintained.

Summary

As competition in the marketplace intensifies, there will be more pressure for networks to support additional applications and the ability for a network to adapt and perform will become more critical. Core network routing represents an area where technology will be asked to deliver much in the way of performance and resiliency. The Passport 1600 Routing Switch meets these challenges head-on by combining resiliency, performance, and security into a high-performance 1 U high solution. With this addition to the Passport LAN portfolio, Nortel Networks continues its position as a complete “end-to-end” enterprise solution company.

Technical specifications

Physical specifications

| | |
|---------------|---|
| <i>Weight</i> | Passport 1648T = 12 lbs; Passport 1624G = 13.4 lbs; Passport 1612G = 11 lbs |
| <i>Height</i> | 1.73 in. (44 mm) |
| <i>Width</i> | 17.3 in. (441 mm) |
| <i>Depth</i> | 14.4 in. (368mm) |

Performance specifications

- 1648T Non-blocking Switch Fabric of 24 Gbps providing 13 Mpps
- 1612G Non-blocking Switch Fabric of 24 Gbps providing 18 Mpps
- 1624G Non-blocking Switch Fabric of 48 Gbps providing 36 Mpps

Data rate

- 10 Mbps Manchester encoded or 100 Mbps 4B/5B encoded

Interface options

- 10BASE-T/100BASE-TX: RJ-45 (8-pin modular) connectors for MDI-X interface
- Autosensing/autonegotiating
- SFP (mini) GBICs

| | Distance | Type | | Distance | Type |
|---------------------|----------|--------|---------------|----------|--------|
| 1000BASE-SX (MT-RJ) | 550 m | MMF | 1000BASE CWDM | 70km | 1490nm |
| 1000BASE-SX (LC) | 550 m | MMF | 1000BASE CWDM | 70km | 1510nm |
| 1000BASE-LX | 5 km | SMF | 1000BASE CWDM | 70km | 1530nm |
| 1000BASE-T | 100m | CAT5 | 1000BASE CWDM | 70km | 1550nm |
| 1000BASE CWDM | 40km | 1470nm | 1000BASE CWDM | 70km | 1570nm |
| 1000BASE CWDM | 40km | 1490nm | 1000BASE CWDM | 70km | 1590nm |
| 1000BASE CWDM | 40km | 1510nm | 1000BASE CWDM | 70km | 1610nm |
| 1000BASE CWDM | 40km | 1530nm | | | |
| 1000BASE CWDM | 40km | 1550nm | | | |
| 1000BASE CWDM | 40km | 1570nm | | | |
| 1000BASE CWDM | 40km | 1590nm | | | |
| 1000BASE CWDM | 40km | 1610nm | | | |
| 1000BASE CWDM | 70km | 1470nm | | | |

Network protocol and standards compatibility

- IEEE 802.3 10BASE-T Ethernet (twisted-pair copper)
- IEEE 802.3z Gigabit Ethernet
- IEEE 802.3u 100BASE-TX Fast Ethernet (twisted-pair copper)
- ANSI/IEEE 802.3 Auto-negotiation
- IEEE 802.3x Flow Control
- IEEE 802.1p Priority Queues
- IEEE 802.1Q VLANs
- IEEE 802.1d Spanning Tree
- 802.1v protocol/IP subnet-based VLANs

RFC support

- RFC 768 Unreliable Data gram Protocol (UDP)
- RFC 783 Trivial File Transfer Protocol (TFTP)
- RFC 791/950 Internet Protocol (IP)
- RFC 792 Internet Control Message Protocol (ICMP)
- RFC 826 Address Resolution Protocol (ARP)
- RFC 854 Telnet
- RFC 2236 Internet Group Management Protocol (IGMP) version 2
- RFC 1542 BOOTP
- RFC 1058 Routing Information Protocol (RIP)
- RFC 1519 Classless Inter-domain Routing (CIDR)
- RFC 1723 Routing Information Protocol (RIP) version 2
- RFC 1724 RIPv2 MIB
- RFC 1583 OSPFv2
- RFC 1850 OSPFv2 MIB
- RFC 2131 BOOTP/DHCP relay
- draft-ietf-idmr-dvmrp-v3-10 DVMPv3
- RFC 2338 Virtual Router Redundancy Protocol

—continued

Technical specifications—continued

Electrical specifications

- Power supply AC 100-240V, 50-60Hz, 1.5A max, 1+1 Redundant

Mean Time Between Failure

- Passport 1612G: 177,000 hours
- Passport 1624G: 158,000 hours
- Passport 1648T: 153,000 hours

Electrical specifications

- Operation temperature: 0° to 40°C; 32° to 104°F
- Humidity: 5% to 95%
- 3 built-in 40x40x10 mm fans

Safety agency approvals

- IEC 60950 International CB Certification
- EN 60950 European Certification
- UL60950 US certification
- CSA22.2, #60950 Canadian Certification
- NOM Mexican Certification

Electromagnetic immunity

- EN55024 :1998

Electromagnetic emissions summary

- CISPR22, Class A/CISPR24 International Certification
- EN55022, Class A/EN55024 European
- FCC, Part 15, Class A US Certification
- ICES-003, Class A Canadian Certification
- AN/NZS 3548 Australian/New Zealand Certification
- BSMI - Taiwan - CNS 13438, Class A
- MIC - Korea - MIC, No. 2001-116
- VCCI Japanese Certification

Order information

| Part No. | Description |
|-----------|---|
| DJ1412x02 | Passport 1648T Routing Switch with 48 10/100TX ports and 4 SFP GBIC slots. Dual AC power supply |
| DJ1412x03 | Passport 1612G Routing Switch with 12 SFP GBIC slots. Dual AC power supply |
| DJ1412x04 | Passport 1624G Routing Switch with 24 SFP GBIC slots. Dual AC power supply |
| AA1419013 | 1-port 1000BASE-SX Small Form Factor Pluggable GBIC (mini-GBIC, connector type: LC) |
| AA1419014 | 1-port 1000BASE-SX Small Form Factor Pluggable GBIC (mini-GBIC, connector type: MT-RJ) |
| AA1419015 | 1-port 1000BASE-LX Small Form Factor Pluggable GBIC (mini-GBIC, connector type: LC) |
| AA1419043 | 1-port 1000BASE-T Small Form Pluggable (SFP), 8-pin modular connector (RJ-45) |
| AA1419025 | 1-port 1000BASE CWDM Small Form Factor Pluggable GBIC (mini-GBIC, connector type: LC) - 1470nm Wavelength, 40km |
| AA1419026 | 1-port 1000BASE CWDM Small Form Factor Pluggable GBIC (mini-GBIC, connector type: LC) - 1490nm Wavelength, 40km |
| AA1419027 | 1-port 1000BASE CWDM Small Form Factor Pluggable GBIC (mini-GBIC, connector type: LC) - 1510nm Wavelength, 40km |
| AA1419028 | 1-port 1000BASE CWDM Small Form Factor Pluggable GBIC (mini-GBIC, connector type: LC) - 1530nm Wavelength, 40km |
| AA1419029 | 1-port 1000BASE CWDM Small Form Factor Pluggable GBIC (mini-GBIC, connector type: LC) - 1550nm Wavelength, 40km |
| AA1419030 | 1-port 1000BASE CWDM Small Form Factor Pluggable GBIC (mini-GBIC, connector type: LC) - 1570nm Wavelength, 40km |
| AA1419031 | 1-port 1000BASE CWDM Small Form Factor Pluggable GBIC (mini-GBIC, connector type: LC) - 1590nm Wavelength, 40km |
| AA1419032 | 1-port 1000BASE CWDM Small Form Factor Pluggable GBIC (mini-GBIC, connector type: LC) - 1610nm Wavelength, 40km |
| AA1419033 | 1-port 1000BASE CWDM Small Form Factor Pluggable GBIC (mini-GBIC, connector type: LC) - 1470nm Wavelength, 70km |
| AA1419034 | 1-port 1000BASE CWDM Small Form Factor Pluggable GBIC (mini-GBIC, connector type: LC) - 1490nm Wavelength, 70km |
| AA1419035 | 1-port 1000BASE CWDM Small Form Factor Pluggable GBIC (mini-GBIC, connector type: LC) - 1510nm Wavelength, 70km |
| AA1419036 | 1-port 1000BASE CWDM Small Form Factor Pluggable GBIC (mini-GBIC, connector type: LC) - 1530nm Wavelength, 70km |
| AA1419037 | 1-port 1000BASE CWDM Small Form Factor Pluggable GBIC (mini-GBIC, connector type: LC) - 1550nm Wavelength, 70km |
| AA1419038 | 1-port 1000BASE CWDM Small Form Factor Pluggable GBIC (mini-GBIC, connector type: LC) - 1570nm Wavelength, 70km |
| AA1419039 | 1-port 1000BASE CWDM Small Form Factor Pluggable GBIC (mini-GBIC, connector type: LC) - 1590nm Wavelength, 70km |
| AA1419040 | 1-port 1000BASE CWDM Small Form Factor Pluggable GBIC (mini-GBIC, connector type: LC) - 1610nm Wavelength, 70km |

The seventh character (x) of the switch order number must be replaced with the proper code to indicate desired product nationalization:

- “A” – No power cord included
- “B” – Includes European “Schuko” power cord common in Austria, Belgium, Finland, France, Germany, The Netherlands, Norway, and Sweden
- “C” – Includes power cord commonly used in the United Kingdom and Ireland
- “D” – Includes power cord commonly used in Japan
- “E” – Includes North American power cord
- “F” – Includes Australian power cord, also commonly used in New Zealand and the People’s Republic of China

In the United States:

Nortel Networks
35 Davis Drive
Research Triangle Park, NC 27709
USA

In Canada:

Nortel Networks
8200 Dixie Road
Suite 100
Brampton, Ontario L6T 5P6
Canada

In Caribbean and Latin America:

Nortel Networks
1500 Concorde Terrace
Sunrise, FL 33323
USA

In Europe:

Nortel Networks
Maidenhead Office Park
Westacott Way
Maidenhead Berkshire SL6 3QH
UK

In Asia:

Nortel Networks Asia
6/F Cityplaza 4
Taikooshing
12 Taikoo Wan Road, Hong Kong



BUSINESS WITHOUT BOUNDARIES

Nortel Networks is an industry leader and innovator focused on transforming how the world communicates and exchanges information. The company is supplying its service provider and enterprise customers with communications technology and infrastructure to enable value-added IP data, voice and multimedia services spanning Wireless Networks, Wireline Networks, Enterprise Networks, and Optical Networks. As a global company, Nortel Networks does business in more than 150 countries. More information about Nortel Networks can be found on the Web at:

www.nortelnetworks.com

For more information, contact your Nortel Networks representative, or call 1-800-4 NORTEL or 1-800-466-7835 from anywhere in North America.

*Nortel Networks, the Nortel Networks logo, the globemark design, BayStack, Optivity, and Passport are trademarks of Nortel Networks. All other trademarks are the property of their owners.

Copyright © 2004 Nortel Networks. All rights reserved. Information in this document is subject to change without notice. Nortel Networks assumes no responsibility for any errors that may appear in this document.

NN104000-040804